

SONANCE

PROFESSIONAL SERIES IN-CEILING

PS-C43RT, PS-C63RT, PS-C83RT, PS-C83RWT, PS-C43RTL, PS-C63RTL

MANUAL

IN-CEILING SPEAKERS

PS-C43RT, PS-C63RT, PS-C83RT, PS-C83RWT,
PS-C43RTL, PS-C63RTL

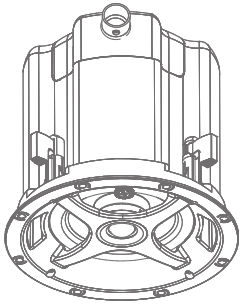

Front View

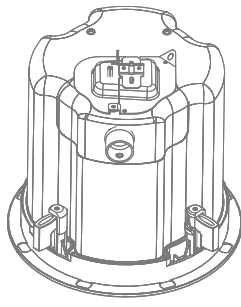

Back View

TABLE OF CONTENTS

| | |
|----|--------------------------------|
| 2 | Box and Contents |
| 3 | Product Features |
| 4 | Amplifier Selection |
| 4 | Wire Selection |
| | 70V/100V System |
| | 8 ohm System |
| 4 | Speaker Placement |
| 4 | Grille Painting |
| 5 | Standard Installation |
| 6 | Drop Ceiling Installation |
| 8 | Technical Specifications |
| 14 | Certifications & Safety Agency |
| 14 | Technical Assistance & Service |
| 15 | Warranty |

BOX CONTENTS

IN-CEILING SPEAKER OR WOOFER

- (1) PS-C43RT, PS-C63RT, PS-C83RT,
 PS-C43RTL, PS-C63RTL, or PS-C83RWT
- (1) Speaker Grille in White (Black Optional)
- (2) Tile Support Rails
- (1) C-Ring
- (1) Cutout Template

IMPORTANT SAFETY INSTRUCTIONS

This product is intended to be installed by professional AV integrators and installers only. This product manual is intended to serve as a general guideline for most applications. It is the installer's responsibility to ensure this product is installed in accordance with local building codes and regulations. Consult a local authority for specific requirements, regulations, and building codes of the jurisdiction in which this product is to be installed.

READ THIS DOCUMENT IN ITS ENTIRETY BEFORE ATTEMPTING USE.

1. Read these instructions.
2. Keep these instructions.
3. Heed all warnings.
4. Follow all instructions.
5. Clean only with a dry cloth.
6. Do not block any ventilation openings. Install in accordance with the manufacturer's instructions.
7. Do not install near a heat source such as radiators, heat registers, stoves, fireplaces, or other apparatus (including amplifiers) that produce heat.
8. To be installed in indoor locations only.
9. Only use attachments/accessories specified by Sonance.
10. Refer all servicing to qualified service personnel.

PRODUCT DESCRIPTION

From Sonance, the company that created the architectural audio category, comes a range of professional loudspeakers that set a new benchmark in sound quality and aesthetics for commercial environments. Sonance Professional Series includes a range of In-Ceiling, Pendant and Surface Mount speakers that deliver true full range fidelity, extremely low distortion, wide dispersion and a smooth power response. The range also shares consistent voicing, ensuring seamless sonic integration when used together throughout a space.

The In-Ceiling speakers feature a one-piece bezel-less grille that is magnetically secured and allows for a one-step painting process to simplify installation and minimize visual distraction. The optional Square Grille Adapter allows the speakers to match the aesthetic of square downlights and HVAC grilles. Sealed metal enclosures, integrated cable and conduit clamping, seismic attachment and connector cover allow them to be installed in commercial environments where UL 1480 and UL 2043 are required by code. Available in 4", 6.5" and 8" 2-Way and 8" Woofer - all shipped with white grille. An optional black grille and square adapter are also available.

PRODUCT FEATURES

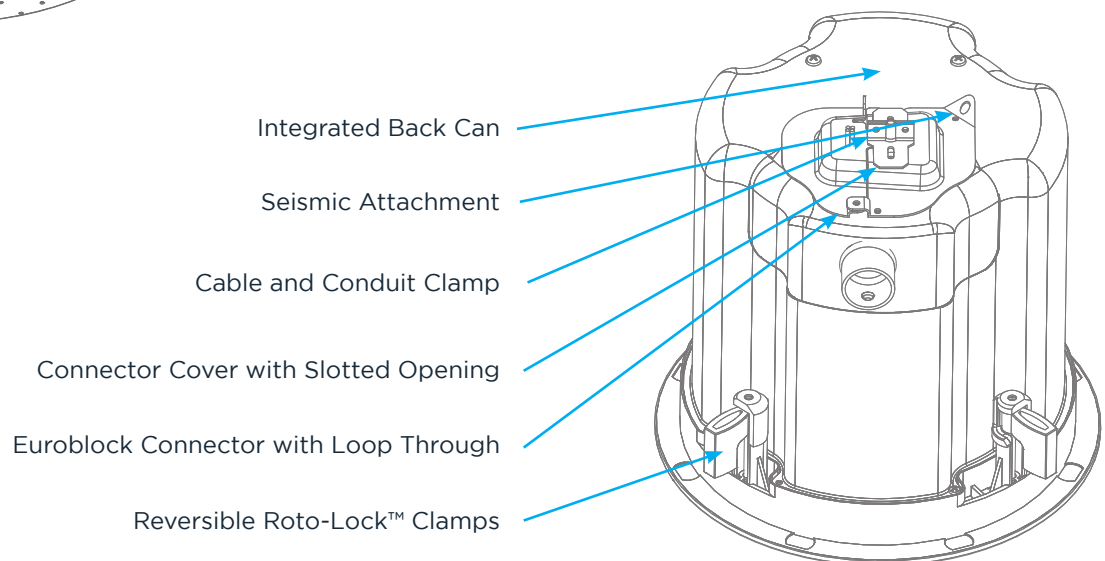
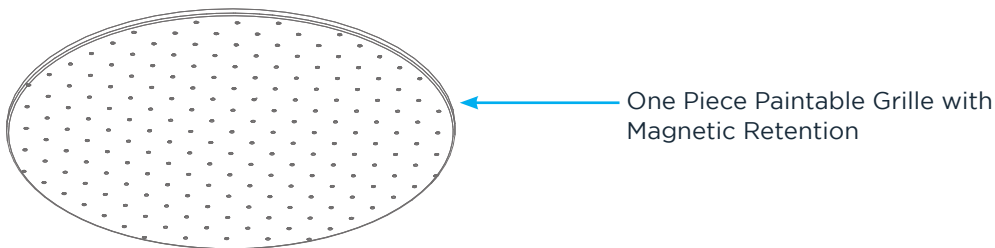
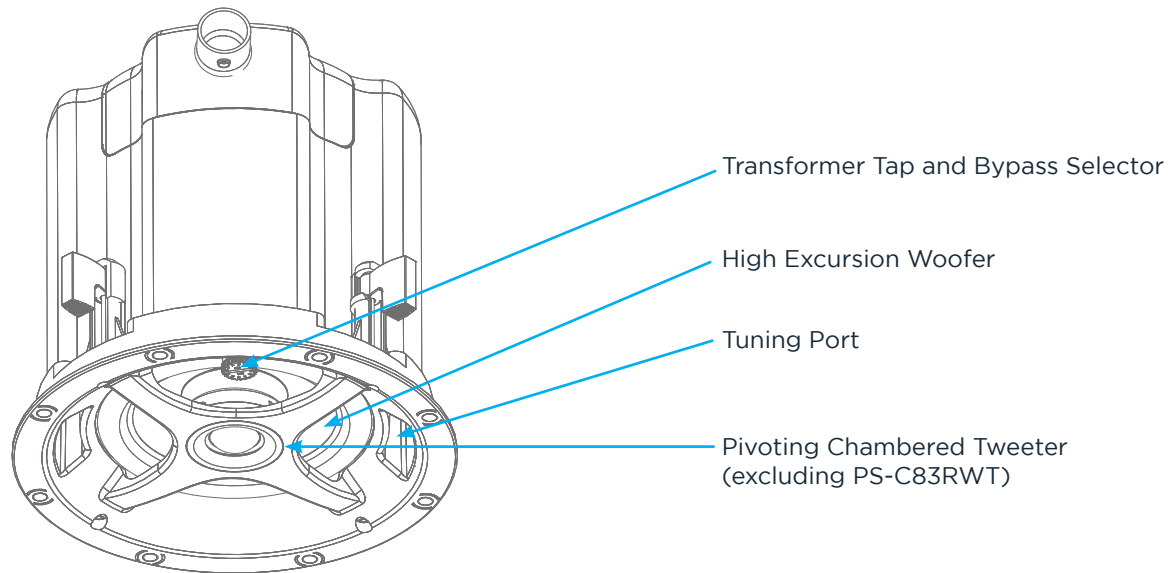

AMPLIFIER SELECTION

When choosing an amplifier the maximum number of speakers and the output level of each speaker must be known. The sum of the tap settings should never exceed 80% of the amplifier's rated output. For example, if there are 5 speakers and the taps are set at 15 watts, the load would be 75 watts (5 x 15 watts = 75 watts). To arrive at the needed power for this number of speakers, simply divide the total load by .8. In this case, $75 / .8 = 93.75$ watts. Therefore, a standard 100 watt amp would safely drive this load. To calculate the amount of usable power an amp offers, simply multiply the rated output by .8, i.e., $100 \text{ watts} \times .8 = 80 \text{ watts}$.

WIRE SELECTION

WIRE GAUGE - 70V/100V SYSTEM

The most common wire used on commercial 70 volt systems is 18 gauge, 2 conductor, stranded, and jacketed without a shield. The wire starts at the amplifier location and is paralleled at each speaker location. Wire length using 18 gauge is appropriate up to 700 feet with a 100 watt load. If you double the load (sum of your tap settings), you will reduce the footage by half, to 350 feet. Conversely, if you halve the load, you may double the acceptable wire length, i.e., a 50 watt load is safe over 1400 feet of 18 gauge. Stepping up to 16 gauge wire extends the allowable run length by approximately 35%. For example, a 100 watt load can go 700 feet on 18 gauge; the same load may be placed on 1100 feet of 16 gauge.

WIRE GAUGE - 8 OHM SYSTEM

When using Sonance Professional Series loudspeakers in an 8 ohm system the total wire resistance should be less than 10% of the speaker impedance. The speakers are nominally 8 ohms impedance, so your total wire resistance should be no more than 0.8 ohms. In simple terms, the extra resistance from the wire will have a very negative affect on the sound quality of the speaker. The sound can be less dynamic, definition of bass frequencies can be reduced, and in extreme cases, the high frequencies can be attenuated. Amplifier power is also wasted in the wire, reducing the maximum output level of the system. Please refer to the following chart (see figure 1) when deciding on the appropriate wire gauge for your installation.

| Wire Resistance in Ohms vs. Length of Cable Run | | | | | | |
|-------------------------------------------------|-----|------|------|------|------|------|
| Distance in Feet | 50' | 100' | 150' | 200' | 250' | 300' |
| 20 Gauge | .86 | 1.73 | 2.59 | 3.45 | 4.32 | 5.18 |
| 18 Gauge | .65 | 1.30 | 1.94 | 2.59 | 3.24 | 3.89 |
| 16 Gauge | .43 | .85 | 1.28 | 1.71 | 2.14 | 2.56 |
| 14 Gauge | .27 | .54 | .81 | 1.08 | 1.35 | 1.62 |
| 12 Gauge | .17 | .34 | .51 | .68 | .85 | 1.02 |

Figure 1: Wire Resistance

SPEAKER PLACEMENT

Sonance Professional Series speakers possess extremely smooth and predictable off-axis frequency response. The chart below (see figure 2) shows how far apart the speakers can be placed in a distributed audio system. The calculations are based on +/- 45 degrees of coverage from the speaker, and listener ear heights of 62" for standing and 40" for seated.

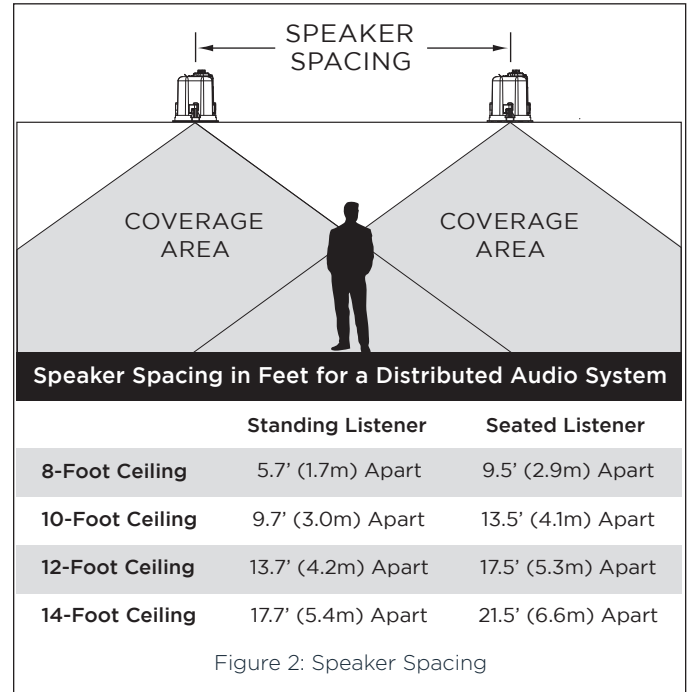

GRILLE PAINTING

BEFORE YOU BEGIN

Sonance Professional Series In-Ceiling speaker grilles completely cover the exposed speaker frame, so only the grilles (not the speakers themselves) require painting.

IMPORTANT: Mask the front flange of the speaker before painting the wall or ceiling (see Figure 3).

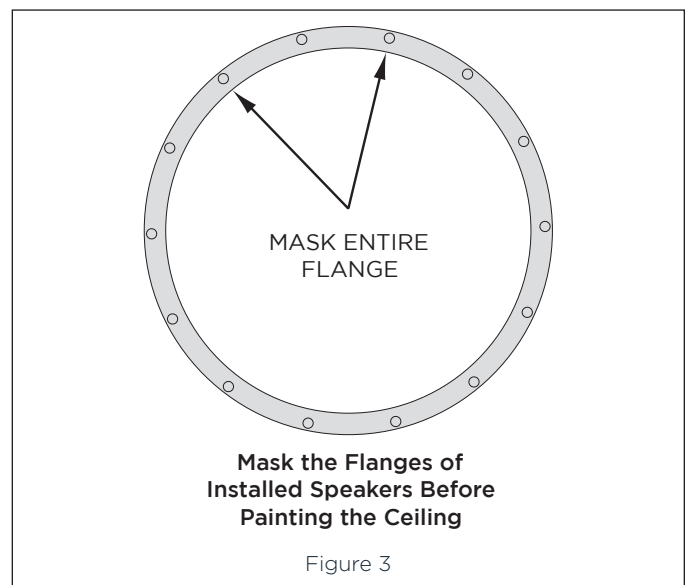

PREPARING THE GRILLES FOR PAINTING

Carefully remove the scrim cloth from the underside of the grille. The scrim cloth is held in place with a light tacking glue. Use a heating agent such as a heat gun or hair dryer to soften the glue and carefully remove the cloth, since you will need to replace it when you're done painting the grille. Be careful not to deform the cloth's shape while removing it - this will make it very difficult to properly replace the cloth on the grille. Remove any adhesive residue from the back of the grille before beginning painting.

PAINTING THE GRILLES

1. Prime the grille with a metal primer/bonder in a spray can. Carefully follow the manufacturer's directions on the can.
2. We recommend using water-based latex paint on the grilles. Thin the paint with a proper thinning agent to a ratio of 1:1 paint-to-thinner, and strain it through a standard mesh strainer to remove any lumps.

IMPORTANT: Due to its increased durability, oil-based paint should be considered for Professional Series Speakers that are installed outdoors.

3. Use a small touch-up gun or cap-spray gun with a #3 tip for painting.
 - Set the nozzle with a medium to wide fan.
 - Set the pressure regulator to 60psi.
 - Lightly spray the front of the grille in three quick strokes from approximately 10" away.
 - Let the paint set for a minute, then turn the grille 90° and lightly spray the grille again in three quick strokes. Repeat this step until all four sides of the grille have been evenly painted.
4. While the paint is still wet, inspect the grille and make sure that excess paint has not collected underneath the grille frame, and that none of the grille perforations are filled with paint. If any are, use compressed air to blow the paint out of the perforations.

IMPORTANT: If you find any grille perforations that are plugged with paint after the paint has dried, use a straight pin or sewing needle to carefully remove the paint.

5. Once the paint has thoroughly dried, replace the scrim cloth on the back of the grille and mount the grille on the speaker.

STANDARD INSTALLATION

1. Cut a hole in the drywall using the supplied cutout template.

NOTE: For drop-ceiling instructions refer to page 7.

2. Connect the wires from your amplifier to the Euroblock connector (see Figure 4).

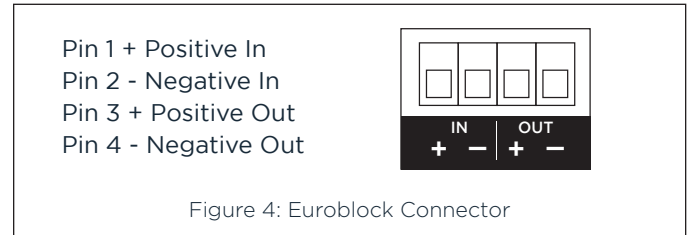

3. Strip approximately 0.1875" (5mm) of the insulation off each wire. Insert the wire into the correct square opening on the connector. Use a small flat head screwdriver to tighten the corresponding screw to secure the wire (see Figure 5).

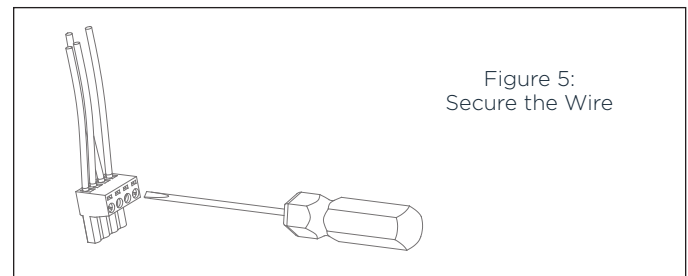

When using multiple speakers you can connect the speakers either in parallel or in the loop through method as shown (see Figure 6 and 7).

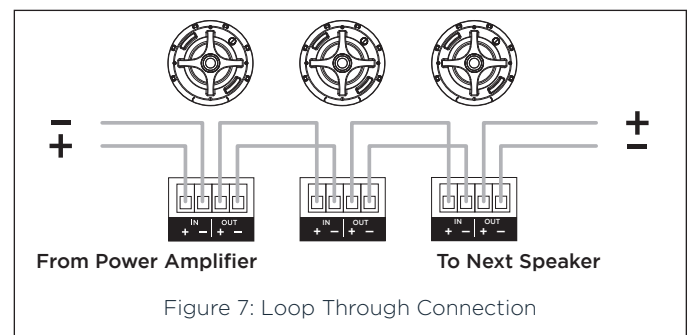
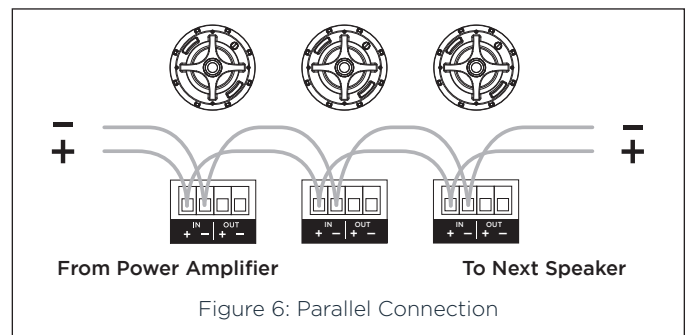

NOTE: If square grilles are being used the adapter frame must be installed at this time.

- Once all the wires are terminated. Plug the green Euroblock connector into the back of the speaker (see Figure 8).

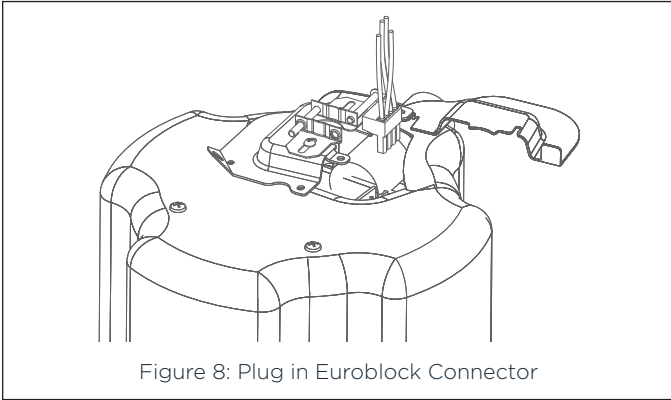

Figure 8: Plug in Euroblock Connector

Route the wires through the Strain Relief Fitting on the back of the speaker. Tighten the screws on the strain relief to clamp the wires. Make sure not to over-tighten the screws and damage the wire (see Figure 9).

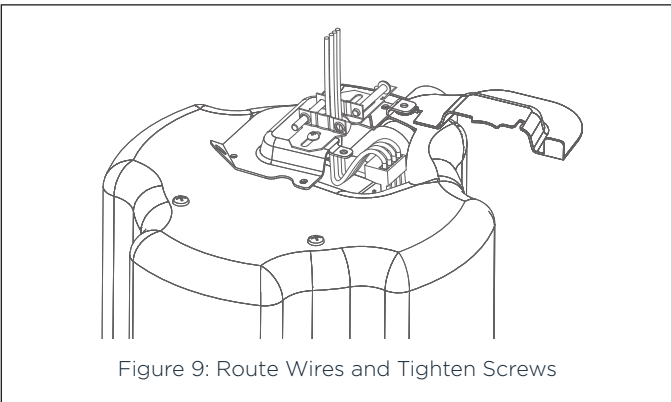

Figure 9: Route Wires and Tighten Screws

- Make sure the Roto-Lock Clamps are in the full clockwise position so that all the clamps are tucked within the cutout border. Insert the speaker into the hole in the ceiling (see Figure 10).

NOTE: The maximum clamp thickness 1.732" (44mm). To achieve maximum thickness, unscrew and reverse the foot of the Roto-Lock Clamps. For details on flex bracket go to www.sonance.com

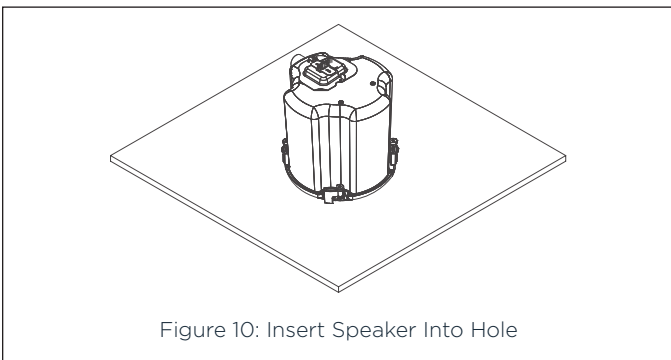

Figure 10: Insert Speaker Into Hole

SAFETY PRECAUTION: Attaching the seismic tab to a support line is highly recommended for additional safety.

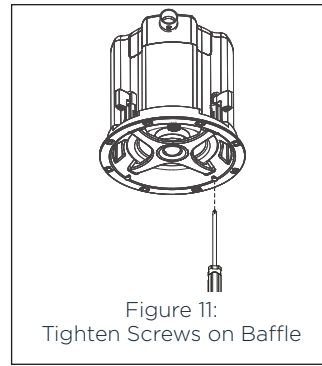

Figure 11:
Tighten Screws on Baffle

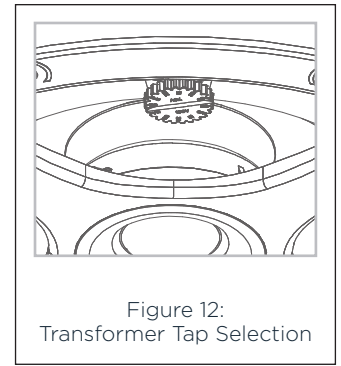

Figure 12:
Transformer Tap Selection

- Tighten the four screws on the front of the baffle. The Roto-Lock Clamps will rotate into position automatically and begin clamping. When you notice resistance on the four screws, the speaker has been clamped successfully (see Figure 11). The flange is designed to flex and conform to any small imperfections in the ceiling surface.
- The transformer tap selector can be set. Depending on your installation you may wait to set the volume of each speaker until the system is completely installed (see Figure 12).

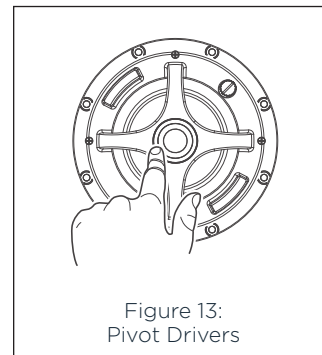

Figure 13:
Pivot Drivers

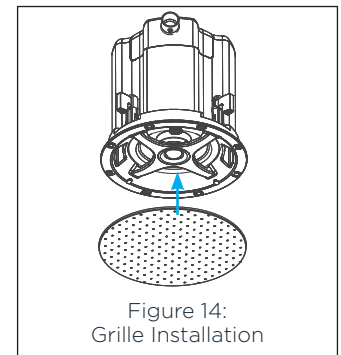

Figure 14:
Grille Installation

- Sonance Professional Series loudspeakers have a pivoting tweeter assembly, allowing the treble to be directed to the most suitable location if the speaker is installed of-axis. To pivot the drivers apply light pressure to the ring around the outside edge of the tweeter cone. Take care not to touch or apply pressure to the cone itself (see Figure 13).
- After the speaker is installed, and transformer tap adjustments are made, the grille can be installed. The grille is held in place by several small, powerful magnets on the speaker frame. Place the grille against the speaker and the magnets will hold it firmly in place. When properly installed, the grille should make contact with the wall all the way around the speaker

DROP CEILING INSTALLATION

- The included C-bracket and tile support rails should be used in all suspended ceiling installations. The C-bracket and tile support rails can also be used in installations when the speakers are mounted into material that will not support their weight. Insert the two tile support rails and C-bracket through the hole

you have cut, placing them as shown. Using the two screws that are supplied, screw the C-bracket to the tile support rails as shown (see Figure 15). After the C-bracket and tile support rails are installed follow Steps 2 through 8 in the standard installation instructions.

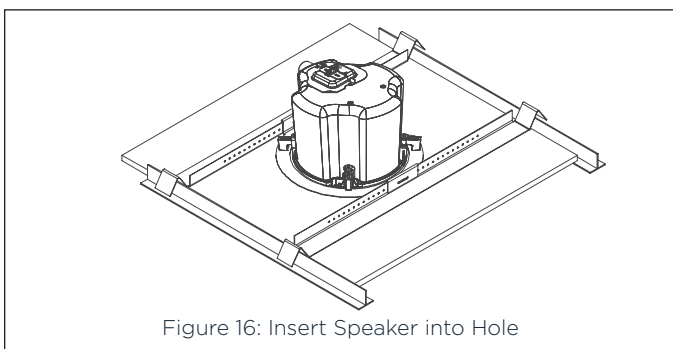
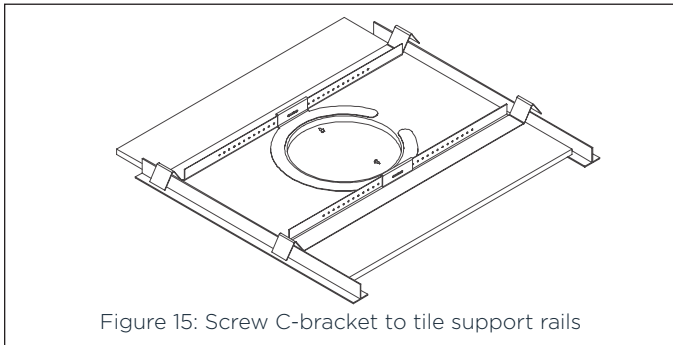

SAFETY PRECAUTION: Attaching the seismic tab to a support line is highly recommended for additional safety.

PS-C43RT TECHNICAL SPECIFICATIONS

| | |
|-------------------------|---------------------------------------------------------------------|
| Frequency Range (-10dB) | 57Hz - 25kHz |
| Frequency Range (-3dB) | 75Hz - 20kHz |
| Power Capacity | 60 Watts Continuous Program Power 30 Watts Continuous Pink Noise |
| Nominal Sensitivity | 87dB |
| Nominal Coverage Angle | 120 degrees conical coverage |
| Directivity Factor (Q) | 7.6 |
| Directivity (DI) | 8.1dB |
| Rated Maximum SPL | 105dB @ 1 meter (3.3 feet) average, 110dB peak |
| Rated Impedance | 8 ohms nominal, 6 ohms minimum |
| Transformer Taps | 70V: 30W, 15W, 7.5W and 3.8W 100V: 30W, 15W and 7.5W |
| Crossover Point | 3000Hz |
| Overall Dimension | 6.3" Diameter x 7.01" Depth (160mm x 178mm) |
| Cut Out Dimension | 5.875" Diameter (149mm) |
| Net Weight | 5.63 lbs (2.55kg) each |
| Shipping Weight | 21.80 lbs (9.89kg) 2x each |
| Unit of Measure | Each |
| Grille | Supplied with bezel-less white grille, black grille optional |
| Transducers | |
| LF Driver | 4" (100mm) Polypropylene Cone, Butyl Rubber Surround |
| HF Driver | 1" (25mm) Cloth Dome, Pivoting, Ferrofluid cooled |
| Enclosure | |
| Input Connectors | Four pin, Euroblock with loop output connections |
| Knockouts | One, side mounted 0.75" |
| Safety Agency | UL 1480, UL 2043, NFPA 90A, NFPA 70 |
| Ceiling Thickness Range | 0.125" - 2" (3mm - 50mm) |
| Suspension Points | One, on top surface |

INCLUDED ACCESSORIES

- (1) C-Ring
- (2) Tile Support Rails
- (1) Cutout Template
- (1) Euroblock Connector
- (1) White Grille

OPTIONAL ACCESSORIES

- (1 Pair) Replacement Round Grille White | 40152
- (1 Pair) Round Grille Black | 40155
- (5 Pairs) Square Adaptor w/ Grille White | 40158
- (1 Pair) Square Adaptor w/ Grille White | 45158
- (5 Pairs) Square Adaptor w/ Grille Black | 40161
- (1 Pair) Square Adaptor w/ Grille Black | 45161
- (5 Pairs) Flex Bracket | 92471
- (6 Pack) Metal Pre-construction Bracket | 40177
- (1 Pair) Tile Support Rails w/ C-Ring | 40172
- (Bag) Replacement RotoLock Feet | 40175

PS-C63RT TECHNICAL SPECIFICATIONS

| | |
|-------------------------|----------------------------------------------------------------------|
| Frequency Range (-10dB) | 49Hz – 25kHz |
| Frequency Range (-3dB) | 65Hz – 20kHz |
| Power Capacity | 120 Watts Continuous Program Power 60 Watts Continuous Pink Noise |
| Nominal Sensitivity | 91dB |
| Nominal Coverage Angle | 120 degrees conical coverage |
| Directivity Factor (Q) | 6.5 |
| Directivity (DI) | 7.9dB |
| Rated Maximum SPL | 108dB @ 1 meter (3.3 feet) average, 116dB peak |
| Rated Impedance | 8 ohms nominal, 6 ohms minimum |
| Transformer Taps | 70V: 60W, 30W, 15W and 7.5W 100V: 60W, 30W and 15W |
| Crossover Point | 2750Hz |
| Overall Dimension | 9.13" Diameter x 8.86" Depth (232mm x 225mm) |
| Cut Out Dimension | 8.25" Diameter (210mm) |
| Net Weight | 9.38 lbs (4.25kg) each |
| Shipping Weight | 32.36 lbs (14.68kg) 2x each |
| Unit of Measure | Each |
| Grille | Supplied with bezel-less white grille, black grille optional |
| Transducers | |
| LF Driver | 6.5" (165mm) Polypropylene Cone, Butyl Rubber Surround |
| HF Driver | 1" (25mm) Cloth Dome, Pivoting, Ferrofluid cooled |
| Enclosure | |
| Input Connectors | Four pin, Euroblock with loop output connections |
| Knockouts | One, side mounted 0.75" |
| Safety Agency | UL 1480, UL 2043, NFPA 90A, NFPA 70 |
| Ceiling Thickness Range | 0.125" - 2" (3mm - 50mm) |
| Suspension Points | One, on top surface |

INCLUDED ACCESSORIES

- (1) C-Ring
- (2) Tile Support Rails
- (1) Cutout Template
- (1) Euroblock Connector
- (1) White Grille

OPTIONAL ACCESSORIES

- (1 Pair) Replacement Round Grille White | 40153
- (1 Pair) Round Grille Black | 40156
- (5 Pairs) Square Adaptor w/ Grille White | 40159
- (1 Pair) Square Adaptor w/ Grille White | 45159
- (5 Pairs) Square Adaptor w/ Grille Black | 40162
- (1 Pair) Square Adaptor w/ Grille Black | 45162
- (5 Pairs) Flex Bracket | 92337
- (6 Pack) Metal Pre-construction Bracket | 40126
- (1 Pair) Tile Support Rails w/ C-Ring | 40173
- (Bag) Replacement RotoLock Feet | 40175

PS-C83RT TECHNICAL SPECIFICATIONS

| | |
|-------------------------|----------------------------------------------------------------------|
| Frequency Range (-10dB) | 41Hz – 25kHz |
| Frequency Range (-3dB) | 55Hz – 20kHz |
| Power Capacity | 160 Watts Continuous Program Power 80 Watts Continuous Pink Noise |
| Nominal Sensitivity | 91dB |
| Nominal Coverage Angle | 120 degrees conical coverage |
| Directivity Factor (Q) | 7.6 |
| Directivity (DI) | 8.1dB |
| Rated Maximum SPL | 110dB @ 1 meter (3.3 feet) average, 116dB peak |
| Rated Impedance | 8 ohms nominal, 6 ohms minimum |
| Transformer Taps | 70V: 60W, 30W, 15W and 7.5W 100V: 60W, 30W and 15W |
| Crossover Point | 2750Hz |
| Overall Dimension | 11.06" Diameter x 9.84" Depth (281mm x 250mm) |
| Cut Out Dimension | 10.125" Diameter (257mm) |
| Net Weight | 13.41 lbs (6.08kg) each |
| Shipping Weight | 43.08 lbs (19.54kg) 2x each |
| Unit of Measure | Each |
| Color | Black or White |
| Grille | Supplied with bezel-less white grille, black grille optional |
| Transducers | |
| LF Driver | 8" (203mm) Polypropylene Cone, Butyl Rubber Surround |
| HF Driver | 1" (25mm) Cloth Dome, Pivoting, Ferrofluid cooled |
| Enclosure | |
| Input Connectors | Four pin, Euroblock with loop output connections |
| Knockouts | One, side mounted 0.75" |
| Safety Agency | UL 1480, UL 2043, NFPA 90A, NFPA 70 |
| Ceiling Thickness Range | 0.125" - 2" (3mm - 50mm) |
| Suspension Points | One, on top surface |

INCLUDED ACCESSORIES

- (1) C-Ring
- (2) Tile Support Rails
- (1) Cutout Template
- (1) Euroblock Connector
- (1) White Grille

OPTIONAL ACCESSORIES

- (1 Pair) Replacement Round Grille White | 40154
- (1 Pair) Round Grille Black | 40157
- (5 Pairs) Square Adaptor w/ Grille White | 40160
- (1 Pair) Square Adaptor w/ Grille White | 45160
- (5 Pairs) Square Adaptor w/ Grille Black | 40163
- (1 Pair) Square Adaptor w/ Grille Black | 45163
- (5 Pairs) Flex Bracket | 92247
- (6 Pack) Metal Pre-construction Bracket | 40125
- (1 Pair) Tile Support Rails w/ C-Ring | 40174
- (Bag) Replacement RotoLock Feet | 40175

PS-C83RWT TECHNICAL SPECIFICATIONS

| | |
|-------------------------|-----------------------------------------------------------------------|
| Frequency Range (-10dB) | 32Hz – 300Hz |
| Frequency Range (-3dB) | 50Hz – 150Hz |
| Power Capacity | 200 Watts Continuous Program Power 125 Watts Continuous Pink Noise |
| Nominal Sensitivity | 89 dB |
| Nominal Coverage Angle | 180 degrees conical coverage |
| Directivity Factor (Q) | N/A |
| Directivity (DI) | N/A |
| Rated Maximum SPL | 110dB @ 1 meter (3.3 feet) average, 116dB peak |
| Rated Impedance | 8 ohms nominal, 6 ohms minimum |
| Transformer Taps | 70V: 120W, 60W, 30W and 15W 100V: 120W, 60W and 30W |
| Crossover Point | 150Hz |
| Overall Dimension | 11.06" Diameter x 9.84" Depth (281mm x 250mm) |
| Cut Out Dimension | 10.125" (257mm) |
| Net Weight | 14.95 lbs (6.78kg) each |
| Shipping Weight | 25.35 lbs (11.50kg) each |
| Unit of Measure | Each |
| Grille | Supplied with bezel-less white grille or black grille option |
| Transducers | |
| LF Driver | 8" (203mm) Polypropylene Cone, Butyl Rubber Surround |
| HF Driver | N/A |
| Enclosure | |
| Input Connectors | Four pin, Euroblock with loop output connections |
| Knockouts | One, side mounted 0.75" |
| Safety Agency | UL 1480, UL 2043, NFPA 90A, NFPA 70 |
| Ceiling Thickness Range | 0.125" - 2" (3mm - 50mm) |
| Suspension Points | One, on top surface |

INCLUDED ACCESSORIES

- (1) C-Ring
- (2) Tile Support Rails
- (1) Cutout Template
- (1) Euroblock Connector
- (1) White Grille

OPTIONAL ACCESSORIES

- (1 Pair) Replacement Round Grille White | 40154
- (1 Pair) Round Grille Black | 40157
- (5 Pairs) Square Adaptor w/ Grille White | 40160
- (1 Pair) Square Adaptor w/ Grille White | 45160
- (5 Pairs) Square Adaptor w/ Grille Black | 40163
- (1 Pair) Square Adaptor w/ Grille Black | 45163
- (5 Pairs) Flex Bracket | 92247
- (6 Pack) Metal Pre-construction Bracket | 40125
- (1 Pair) Tile Support Rails w/ C-Ring | 40174
- (Bag) Replacement RotoLock Feet | 40175

PS-C43RTLTP TECHNICAL SPECIFICATIONS

| | |
|-------------------------|---------------------------------------------------------------------|
| Frequency Range (-10dB) | 57Hz - 25kHz |
| Frequency Range (-3dB) | 75Hz - 20kHz |
| Power Capacity | 60 Watts Continuous Program Power 30 Watts Continuous Pink Noise |
| Nominal Sensitivity | 87dB |
| Nominal Coverage Angle | 120 degrees conical coverage |
| Directivity Factor (Q) | 7.6 |
| Directivity (DI) | 8.1dB |
| Rated Maximum SPL | 105dB @ 1 meter (3.3 feet) average, 110dB peak |
| Rated Impedance | 8 ohms nominal, 6 ohms minimum |
| Transformer Taps | 70V: 30W, 15W, 7.5W and 3.8W 100V: 30W, 15W and 7.5W |
| Crossover Point | 3000Hz |
| Overall Dimension | 9.13" Diameter x 3.43" Depth (232mm x 87mm) |
| Cut Out Dimension | 8.25" Diameter (210mm) |
| Net Weight | 6 lbs (2.72kg) each |
| Shipping Weight | 25.6 lbs (11.62kg) 2x each |
| Unit of Measure | Each |
| Grille | Supplied with bezel-less white grille, black grille optional |
| Transducers | |
| LF Driver | 4" (100mm) Polypropylene Cone, Butyl Rubber Surround |
| HF Driver | 1" (25mm) Cloth Dome, Pivoting, Ferrofluid cooled |
| Enclosure | |
| Input Connectors | Four pin, Euroblock with loop output connections |
| Knockouts | One, side mounted 0.75" |
| Safety Agency | UL 1480, UL 2043, NFPA 90A, NFPA 70 |
| Ceiling Thickness Range | 0.125" - 2" (3mm - 50mm) |
| Suspension Points | One, on top surface |

INCLUDED ACCESSORIES

- (1) C-Ring
- (2) Tile Support Rails
- (1) Cutout Template
- (1) Euroblock Connector
- (1) White Grille

OPTIONAL ACCESSORIES

- (1 Pair) Replacement Round Grille White | 40153
- (1 Pair) Round Grille Black | 40156
- (5 Pairs) Square Adaptor w/ Grille White | 40159
- (1 Pair) Square Adaptor w/ Grille White | 45159
- (5 Pairs) Square Adaptor w/ Grille Black | 40162
- (1 Pair) Square Adaptor w/ Grille Black | 45162
- (5 Pairs) Flex Bracket | 92337
- (6 Pack) Metal Pre-construction Bracket | 40126
- (1 Pair) Tile Support Rails w/ C-Ring | 40173
- (Bag) Replacement RotoLock Feet | 40175
- (5 Pairs) Retro Ring | 40180

PS-C63RTLTP TECHNICAL SPECIFICATIONS

| | |
|-------------------------|----------------------------------------------------------------------|
| Frequency Range (-10dB) | 49Hz – 25kHz |
| Frequency Range (-3dB) | 65Hz – 20kHz |
| Power Capacity | 120 Watts Continuous Program Power 60 Watts Continuous Pink Noise |
| Nominal Sensitivity | 91dB |
| Nominal Coverage Angle | 120 degrees conical coverage |
| Directivity Factor (Q) | 6.5 |
| Directivity (DI) | 7.9dB |
| Rated Maximum SPL | 108dB @ 1 meter (3.3 feet) average, 116dB peak |
| Rated Impedance | 8 ohms nominal, 6 ohms minimum |
| Transformer Taps | 70V: 60W, 30W, 15W and 7.5W 100V: 60W, 30W and 15W |
| Crossover Point | 2750Hz |
| Overall Dimension | 11.06" Diameter x 4.37" Depth (281mm x 111mm) |
| Cut Out Dimension | 10.125" Diameter (257mm) |
| Net Weight | 10 lbs (4.53kg) each |
| Shipping Weight | 38 lbs (17.23kg) 2x each |
| Unit of Measure | Each |
| Grille | Supplied with bezel-less white grille, black grille optional |
| | |
| Transducers | |
| LF Driver | 6.5" (165mm) Polypropylene Cone, Butyl Rubber Surround |
| HF Driver | 1" (25mm) Cloth Dome, Pivoting, Ferrofluid cooled |
| | |
| Enclosure | |
| Input Connectors | Four pin, Euroblock with loop output connections |
| Knockouts | One, side mounted 0.75" |
| Safety Agency | UL 1480, UL 2043, NFPA 90A, NFPA 70 |
| Ceiling Thickness Range | 0.125" - 2" (3mm - 50mm) |
| Suspension Points | One, on top surface |

INCLUDED ACCESSORIES

- (1) C-Ring
- (2) Tile Support Rails
- (1) Cutout Template
- (1) Euroblock Connector
- (1) White Grille

OPTIONAL ACCESSORIES

- (1 Pair) Replacement Round Grille White | 40154
- (1 Pair) Round Grille Black | 40157
- (5 Pairs) Square Adaptor w/ Grille White | 40160
- (1 Pair) Square Adaptor w/ Grille White | 45160
- (5 Pairs) Square Adaptor w/ Grille Black | 40163
- (1 Pair) Square Adaptor w/ Grille Black | 45163
- (5 Pairs) Flex Bracket | 92247
- (6 Pack) Metal Pre-construction Bracket | 40125
- (1 Pair) Tile Support Rails w/ C-Ring | 40174
- (Bag) Replacement RotoLock Feet | 40175

CERTIFICATIONS

SAFETY AGENCY COMPLIANCE

Sonance Professional Series loudspeakers models PS-C43RT, PS-C63RT, PS-C83RT, PS-C83RWT, PS-C43RTLTP, & PS-C63RTLTP, meet the following standards:

UL 1480: Listed Standard For Safety For Speakers for Fire Alarm, Emergency, and Commercial and Professional Use.

UL 2043: Suitable for use in air-handling spaces.

NFPA 70: 2002 National Electrical Code

NFPA 90A: Installation of Air Conditioning and Ventilation Systems, Section 2-3. 10. (A)



TECHNICAL ASSISTANCE AND SERVICE

The Technical Assistance Department at Sonance is available at (949) 492-7777 to answer any questions concerning the operation and installation of your speakers between the hours of 7:00 AM and 5:00 PM Pacific time, Monday through Friday, except holidays.

In the event your unit should need repair or service, you may return the unit to your authorized dealer or use the following guidelines:

PLEASE KEEP ORIGINAL PACKAGING WHEN POSSIBLE.

1. Be prepared to state the model number and / or serial number, date of purchase, and dealer's name and address when calling.
2. Contact Sonance directly at (949) 492-7777 or at www.sonance.com. **YOU MUST HAVE PRIOR AUTHORIZATION TO RETURN YOUR UNIT.**
3. If you are returning the product directly to Sonance, call us to obtain a return authorization number (RMA) before shipping.
4. Ship the product via United Parcel Service, Federal Express, or other package delivery service. Please do not use the U.S. Postal Service.
5. Include the return authorization number on the shipping label. Please do not write the RMA number directly on the carton.
6. Ship to:

Attn: Quality Assurance Department
RMA# (include RMA number here)
Sonance
11016 Mulberry Ave.
Suite B
Fontana, CA 92337

LIMITED FIVE (5) YEAR WARRANTY

Sonance warrants to the first end-user purchaser that this Sonance-brand product ("Product"), when purchased from an authorized Sonance Dealer/Distributor, will be free from defective workmanship and materials for the period stated below. Sonance will at its option and expense during the warranty period, either repair the defect or replace the Product with a new or remanufactured Product or a reasonable equivalent.

EXCLUSIONS

TO THE EXTENT PERMITTED BY LAW, THE WARRANTY SET FORTH ABOVE IS IN LIEU OF, AND EXCLUSIVE OF, ALL OTHER WARRANTIES, EXPRESS OR IMPLIED, AND IS THE SOLE AND EXCLUSIVE WARRANTY PROVIDED BY SONANCE. ALL OTHER EXPRESS AND IMPLIED WARRANTIES, INCLUDING THE IMPLIED WARRANTIES OF MERCHANTABILITY, IMPLIED WARRANTY OF FITNESS FOR USE, AND IMPLIED WARRANTY OF FITNESS FOR A PARTICULAR PURPOSE ARE SPECIFICALLY EXCLUDED.

No one is authorized to make or modify any warranties on behalf of Sonance. The warranty stated above is the sole and exclusive remedy and Sonance's performance shall constitute full and final satisfaction of all obligations, liabilities and claims with respect to the Product.

IN ANY EVENT, SONANCE SHALL NOT BE LIABLE FOR CONSEQUENTIAL, INCIDENTAL, ECONOMIC, PROPERTY, BODILY INJURY, OR PERSONAL INJURY DAMAGES ARISING FROM THE PRODUCT, ANY BREACH OF THIS WARRANTY OR OTHERWISE.

This warranty statement gives you specific legal rights, and you may have other rights which vary from state to state. Some states do not allow the exclusion of implied warranties or limitations of remedies, so the above exclusions and limitations may not apply. If your state does not allow disclaimer of implied warranties, the duration of such implied warranties is limited to period of Sonance's express warranty. Your Product Model and Description: PS-C41RT / PS-C61RT. Warranty Period for this Product: Five (5) years from the date on the original sales receipt or invoice or other satisfactory proof of purchase. Additional Limitations and Exclusions from Warranty Coverage: The warranty described above is non-transferable, applies only to the initial installation of the Product, does not include installation of any repaired or replaced Product, does not include damage to allied or associated equipment which may result for any reason from use with this Product, and does not include labor or parts caused by accident, disaster, negligence, improper installation, misuse (e.g. overdriving the amplifier or speaker, excessive heat, cold or humidity), or from service or repair which has not been authorized by Sonance. Obtaining Authorized Service: To qualify for the warranty, you must contact your authorized Sonance Dealer/Installer or call Sonance Customer Service at (949) 492-7777 within the warranty period, must obtain a return merchandise number (RMA), and must deliver the Product to Sonance shipping prepaid during the warranty period, together with the original sales receipt, or invoice or other satisfactory proof of purchase.