

# SONANCE

## PROFESSIONAL SERIES PENDANT SPEAKERS QUICKSTART GUIDE

### BOX CONTENTS

- (1) PS-P43T, PS-P63T, PS-P83T, or PS-P83WT
- (1) Speaker Grille
- (1) Screw-On Top Cover
- (1) Hanging Kit Containing:
  - (2) Stainless Steel Cables with Snap Hooks
  - (2) Gripple® Hangers
  - (1) Gripple® Adjustment Tool
  - (1) Hanging Instructions

### CARRYING CAPACITY OF GRIPPLE FASTENERS

Pendant speakers are supplied with Gripple hangers and suspension hardware that exceeds the required weight requirements (see Figure 1 and separate hanging hardware instruction sheet).

GRIPPLE FASTENERS CARRYING CAPACITY		
MODEL	kg	lb
PS-P43T	3.01	6.64
PS-P63T	5.48	12.08
PS-P83T   PS-P83WT	8.50	18.74

Figure 1: Gripple Fasteners Carrying Capacity

### INSTALLING THE SPEAKERS USING GRIPPLE SUSPENSION SYSTEM

**CAUTION:** Installation must be done by qualified persons using safe rigging standards. Use equipment only in accordance with manufacturer's instructions. Do not alter or modify. Do not use equipment if the equipment is not functioning correctly or if the equipment is defective.

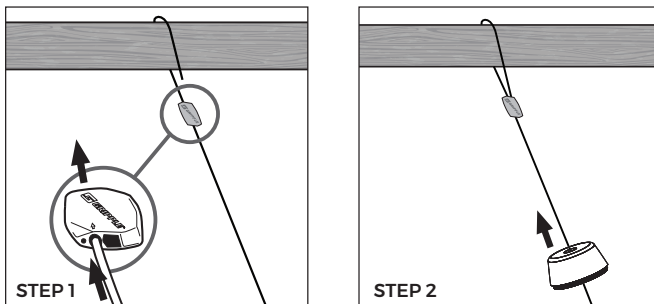

**STEP 1:** Thread Gripple onto cable. Pass over ceiling anchor point or through other secure anchor point of the building structure. Installer is responsible for ensuring that anchor point is secure to building structure.

**STEP 2:** Thread cable through top cover of speaker.

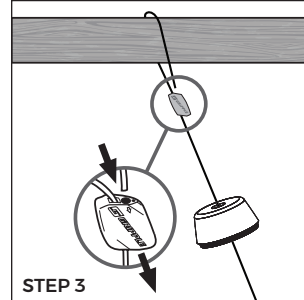

**STEP 3:** Pass tail end of cable through the other channel of the Gripple.

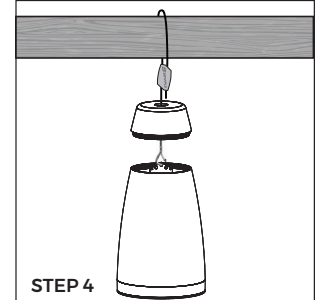

**STEP 4:** With speaker supported, snap main support hook hanger onto the center hole in the top bracket of the speaker. Adjust to proper height by pulling cable through either end of Gripple.

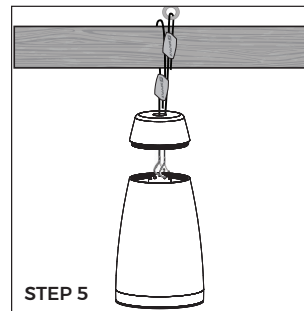

**STEP 5:** Snap secondary support safety cable hook hanger onto one of the side holes in the top bracket, and attach the top to a different ceiling support point of the building structure, per steps 1 and 2.

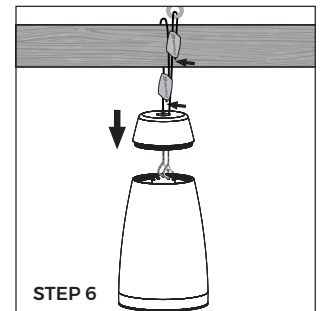

**STEP 6:** After height adjustment is final, trim any extra cable tail wires with trimmer suitable for 2mm (0.077") diameter stranded aircraft-type cable. Screw back on top cover of speaker after speaker wire is connected.

### ADJUSTING SPEAKER HEIGHT

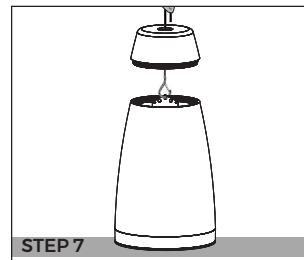

**STEP 7:** Make sure the weight of the load is supported.

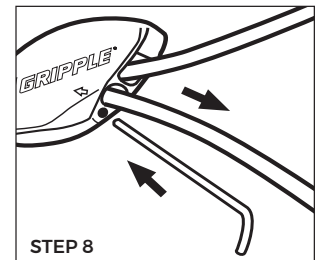

**STEP 8:** Insert key into small hole at bottom of Gripple. Push in 0.25" (6.35mm) to release the cable.

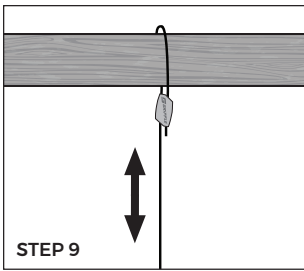

STEP 9

**STEP 9:** Adjust height.

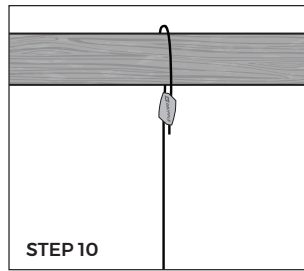

STEP 10

**STEP 10:** Remove key and re-secure the load.

**IMPORTANT:** Speaker wire must have 12" (305mm) of extra length to act as a strain relief to prevent the Euroblock connector from becoming disconnected.

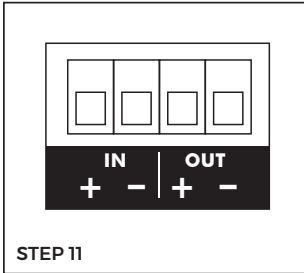

STEP 11

**STEP 11:** Connect the wires from your amplifier to the Euroblock connector.

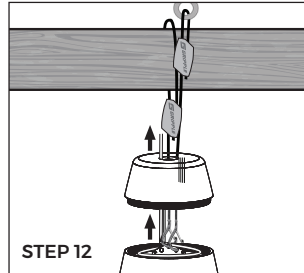

STEP 12

**STEP 12:** Feed speaker wire through the hole in the top of the Screw-On Top Cover. Determine length of wire needed to the connector. Add 12" (305mm) extra for strain relief.

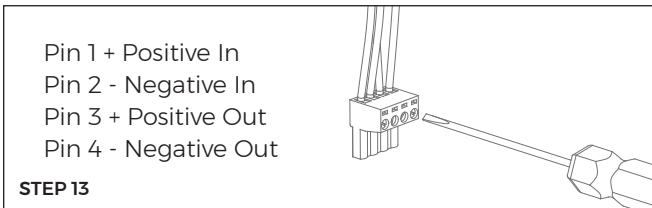

STEP 13

**STEP 13:** Strip approximately .1875" (5mm) of the insulation off each wire. Add the rubber guard onto the wire. Insert the wire into the correct square opening on the connector. Use a small flat head screwdriver to tighten the corresponding screw to secure the wire.

**STEP 14:** When using multiple speakers you can connect the speakers either in parallel or in the loop through method as shown below (see Figure 2 and 3).

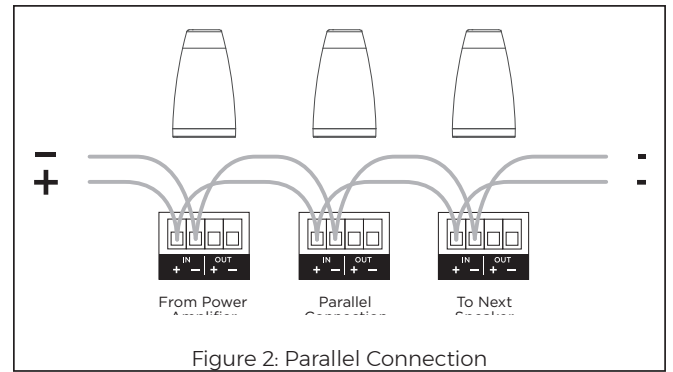

Figure 2: Parallel Connection

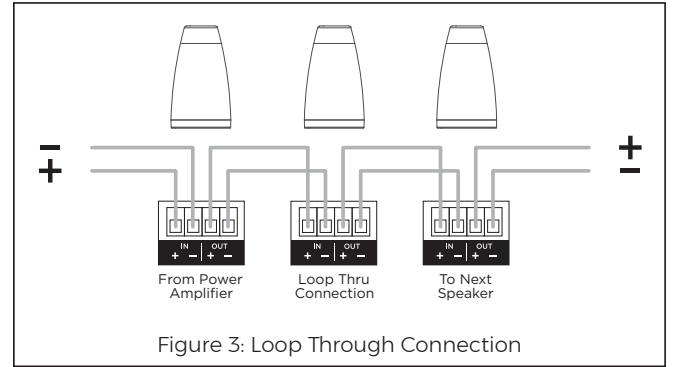
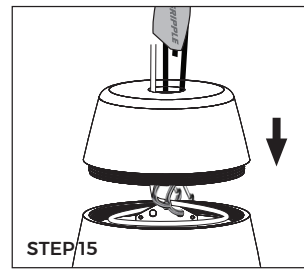
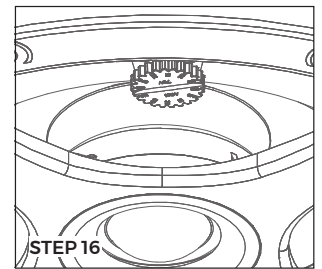

Figure 3: Loop Through Connection



STEP 15

**STEP 15:** Lay the extra wire slack in a coiled circle on the top of the speaker enclosure. Secure the top cover onto the speaker, covering the coiled wire. The extra wire will act as a strain relief.



STEP 16

**STEP 16:** Determine the proper wattage setting for each speaker in the installation and set each speaker's transformer tap selector on the front of the speaker accordingly.

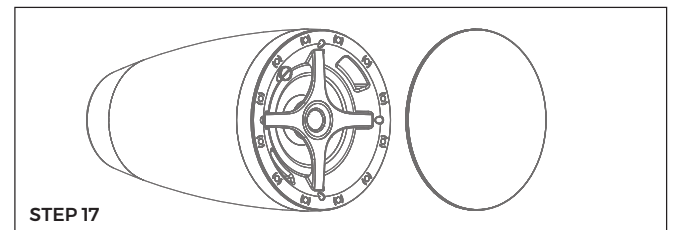

STEP 17

**STEP 17:** Fit the grille onto the speaker.



For warranty information and detailed installation support, access the full manual here. For technical support call 949.492.7777 or visit [www.sonance.com](http://www.sonance.com)

©2025 Sonance. All rights reserved. Sonance is a registered trademark of Dana Innovations. Due to continuous product improvement, all features and specifications are subject to change without notice. For the latest Sonance product specification information visit our website: [www.sonance.com](http://www.sonance.com)

SONANCE • 991 Calle Amanecer • San Clemente, CA 92673 • (949) 492-7777  
UK IMPORTER • Habitech Ltd. • The London Centre • Wade Road, Basingstoke, Hampshire, RG24 8FL • 01.17.2025